

Spec Data Sheet

Acoustical Silencers Non - Erosive Circular Series

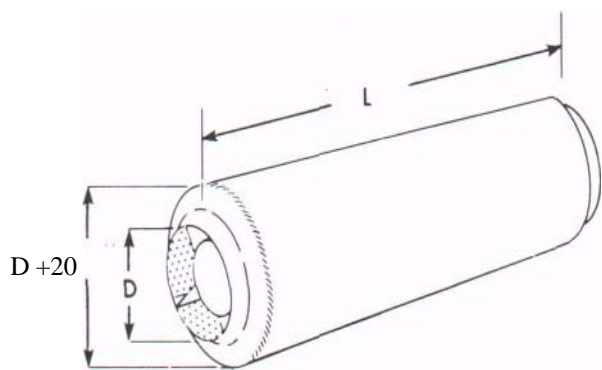

MODEL NF - SDS20

CIRCULAR

NOMENCLATURE EXAMPLE

DIAMETER	LENGTH	MODEL
24 Ø	48	NF - SDS20

Commercial Acoustics products are engineered to deliver superior sound attenuation. Their effectiveness is driven by their quality construction and material components. Each Commercial Acoustic sound attenuator utilizes an innovative engineered metallic material called Feltmetal. The unique interlocked structure of Feltmetal's metal fibers are bonded at all the points where the fibers contact each other. This structural continuity of the fibrous network provides exceptional mechanical properties at low and intermediate densities compared to other sintered, non-fibrous material structures.

MODEL NO.	OCTAVE BANDS CENTER FREQUENCY (Hz)	(1)	(2)	(3)	(4)	(5)	(6)	(7)	(8)
		63	125	250	500	1000	2000	4000	8000
	FACE VELOCITY FPM	DYNAMIC INSERTION LOSS IN DECIBELS							
NF-SDS20-HP	-2000	9	16	28	28	20	19	16	17
	-1000	8	16	27	28	20	19	17	17
	0	9	15	28	28	20	21	17	18
	+1000	7	13	26	27	19	20	18	18
	+2000	7	13	26	27	19	21	18	19
NF-SDS20-LP	-2000	8	13	26	25	14	14	12	13
	-1000	7	14	15	15	14	15	14	15
	0	8	15	31	25	14	15	12	13
	+1000	7	11	25	24	13	15	12	13
	+2000	7	11	24	24	13	15	12	13

THIS TABLE CONTAINS BOTH FORWARD (+) AND REVERSE (-) FLOW ACOUSTIC AND AERODYNAMIC RATINGS BASED ON TEST RESULTS MEASURED IN ACCORDANCE WITH ASTM E477. COPIES OF THESE TEST REPORTS CAN BE FURNISHED UPON REQUEST

INPLANT ENVIRO-SYSTEMS 2000, INC.

105 W. Lynn Street, PO Box 770, St Paris, Ohio 43072
Phone: (877)248-8640 Fax : (937)663-0678